

## Model# 0210-Q

### Two Handle Leg Tub Faucet

#### FEATURES & SPECIFICATIONS

- 4-Arm Handles
- 3/4-14 NPS Male Inlets
- Quick-Presson Quarter-Turn Stems, Replaceable Seat
- 2-Hole 3-3/8" Installation
- Adjustable Flanges

#### FINISHES

- PC Polished Chrome

#### STANDARDS

- ASME A112.18.1



#### WARRANTY

- Lifetime Limited Warranty
- Lifetime Residential Warranty
- 5 Year Commercial Warranty

0210-Q/REV. 11 2016

Product Specifications subject to change without notice

Job Name \_\_\_\_\_ Date \_\_\_\_\_  
Model Specified \_\_\_\_\_ QTY \_\_\_\_\_  
Customer/Wholesaler \_\_\_\_\_  
Contractor \_\_\_\_\_  
Architect/Engineer \_\_\_\_\_  
Submitted as Shown \_\_\_\_\_  
Submitted w/ Variations \_\_\_\_\_

## Model# 0210-Q

### Two Handle Leg Tub Faucet

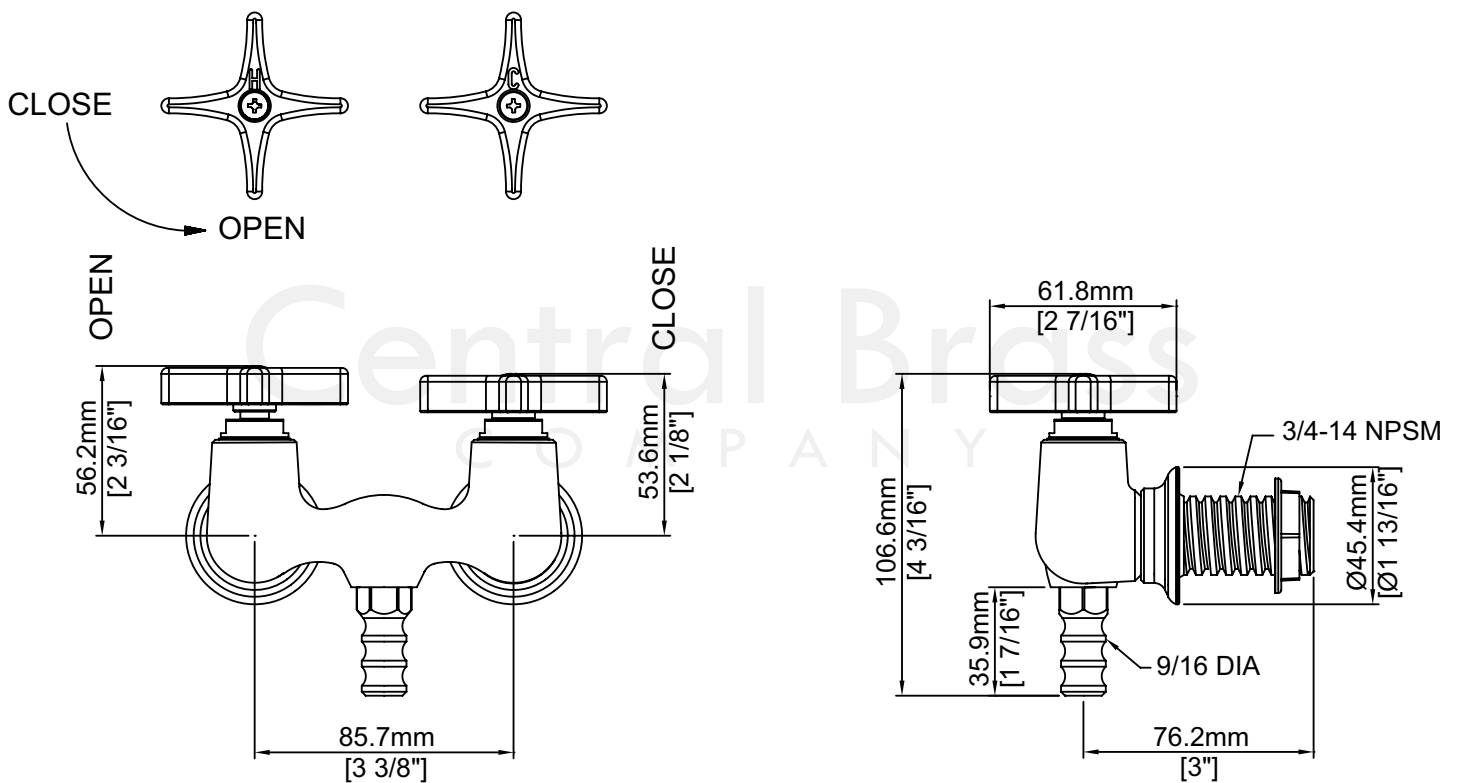

0210-Q/REV. 11 2016

Product Specifications subject to change without notice